

Redirack



*REDIRACK
STORAGE SYSTEMS
FOR LIFE!*

RediDeck

Redirack is manufacturer of storage systems since 1952 (CORNIX group)

REDIDECK® • MEZZANINES

Various types of mezzanines are available : low or high loads, small or big spans, shelving system or pallet racking below or even a completely open space below. Briefly a mezzanine is always bespoke and is conceived taking into account your needs. Below you can find an outline of the different types of mezzanines we can offer you.

**A MEZZANINE DOUBLES YOUR AVAILABLE SPACE
AND ON TOP OF THAT WHEN YOU MOVE ELSEWHERE YOU JUST TAKE IT WITH YOU !
CONSULT US FOR AN ANALYSIS OF YOUR STORAGE NEEDS AND FOR A FREE QUOTE !
ASK FOR THE VISIT OF ONE OF OUR PROJECT ENGINEERS !**

MEZZANINE BASED ON THE REDITAB® PLUS SYSTEM

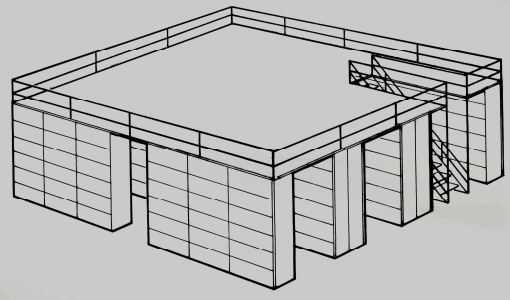

RediTab® Plus shelving system below for the storage of small parts and an open mezzanine upstairs for the storage of bulkier goods on pallets or not.

The mezzanine is built on top of the shelving system.



For the most up to date price : please consult us

MEZZANINE BASED ON THE REDISPAN® SYSTEM

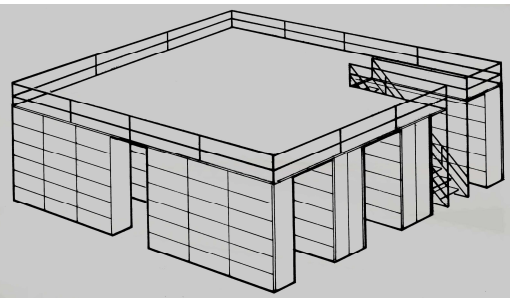

Long span RediSpan® shelving system below, for the storage of small parts or even bulkier goods, an open mezzanine floor upstairs allowing you to store the bulkier merchandise on pallets or not.

The mezzanine is built on top of the longspan shelving system.

MEZZANINE BASED ON THE REDIRACK® SYSTEM - pallet racking

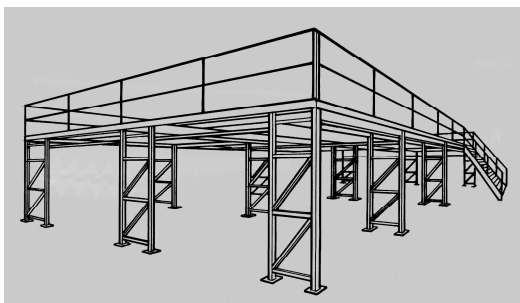

Heavy RediRack® pallet racking allowing you to store heavy and/or bulky goods below, even on pallets.

Open mezzanine upstairs for storage of heavy and/or bulky goods on pallets or not.

This mezzanine is built on the RediRack® pallet racking system.

This type of mezzanine allows you to install any type of shelving system on the ground floor.

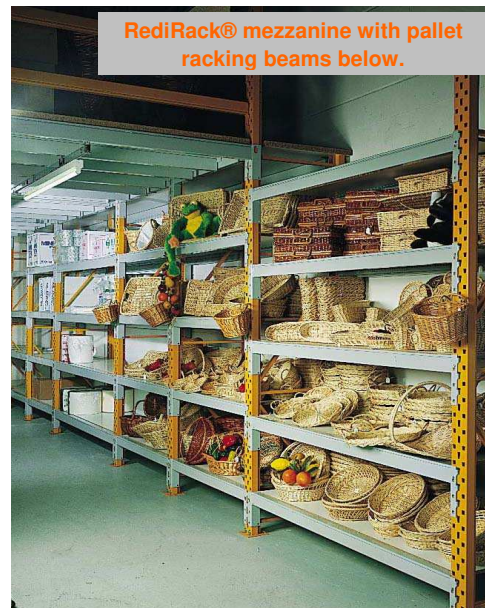

MEZZANINE BASED ON THE REDIRACK® SYSTEM - on columns

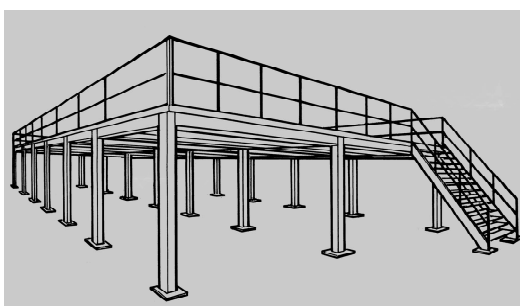

RediRack® columns allow you to store any type of goods below your mezzanine.

Upstairs the open space allows you to store heavy and/or bulky goods or even pallets.

This type of mezzanine gives you the possibility to install any type of storage system below.



Mezzanine built on RediRack® columns with RediTab® Plus shelving below secured by REDIRACK® mesh partitioning and ALUMEL office partitioning upstairs.

LONG SPAN MEZZANINE - on columns

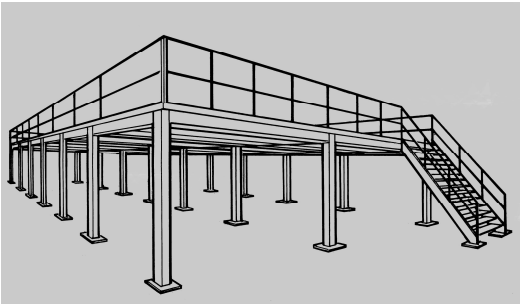

The type A220/A300 & M500 mezzanines are used in case of longer spans and/or higher required load capacities. In most cases the load capacity will be no less than 500 kg/m² and often it will mount up 1500 or even 2000 kg/m². The spans usually will be around 6 meter but obviously longer spans are no problem especially when they are required to optimize the available space on the ground level of your mezzanine. A full range of accessories are available : staircases, handrail, pallet safety gate, handrail loading gate, emergency ladder, etc



3 tier installation, open space both below and upstairs the mezzanine, equipped with a removable handrail & two steel staircases.



3 tier installation partially open and partially equipped with the RediTab® shelving system. Equipped with handrail, staircases and a safety gate for pallet loading.

SAFETY GATE FOR PALLET LOADING



For each mezzanine on which pallets will be stored a pallet safety gate is an absolute security must. Put your pallets onto your mezzanine in all safety without, even temporarily, removing your handrail system.

REDIRACK® ADVICE

Mind the heights : a RediTab® Plus or RediSpan® mezzanine requires +/- 2250 mm under the mezzanine. The mezzanine floor itself is +/- 100 mm high. The total available height required for a two tier installation will have to be at least 4500 mm.

A RediRack® or LONG SPAN mezzanine requires a higher available height as the floor height itself will vary between 200 and 400 or more mm depending on the type of installation.

Delivered unassembled.
On request our specialized installers will install your mezzanine and it's accessories.
Ask for a free quote !



**EUROPE'S FIRST MANUFACTURER
OF STORAGE SYSTEMS**

REDIDECK® • MULTI TIER INSTALLATIONS

Various possibilities depending on your storage needs : highbay, two, three, four or more tier.
RediTab® shelving system, RediSpan® long span shelving or the heavy RediRack® system.
For the storage of all kind of goods, archives, garments etc.



**A MULTI TIER INSTALLATION DOUBLES, TRIPLES, YOUR AVAILABLE SPACE
AND ON TOP OF THAT WHEN YOU MOVE ELSEWHERE YOU JUST TAKE IT WITH YOU !
CONSULT US FOR AN ANALYSIS OF YOUR STORAGE NEEDS AND FOR A FREE QUOTE !
ASK FOR THE VISIT OF ONE OF OUR PROJECT ENGINEERS !**

1 TIER - HIGHBAY



small parts storage with RediTab® Plus shelving system and adapted stacker

Highbay is most often built with the RediTab® Plus shelving system or the RediSpan® long span system.
For the storage of small parts, archives, etc.
Highbay can of course also be built on the RediRack® pallet racking system.



pallet storage with RediRack® highbay



archive storage with RediSpan® and mesh safety guard

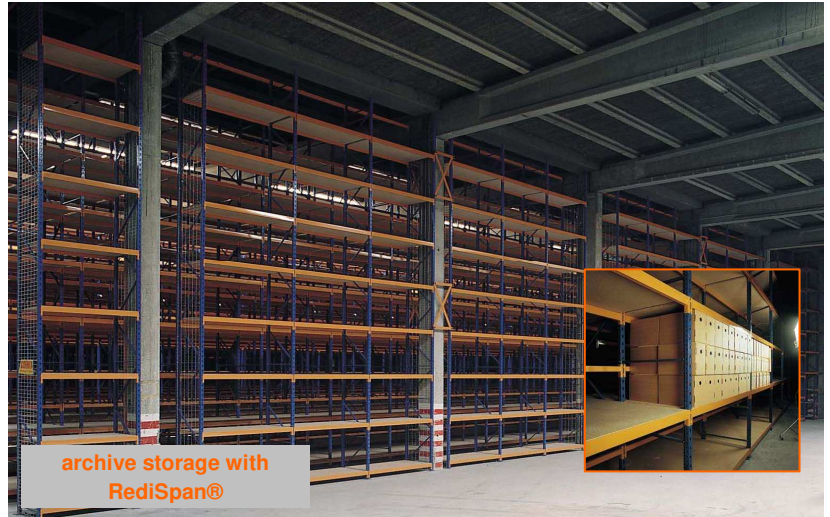

archive storage with RediSpan®

REDIRACK® ADVICE

**Mind the heights : a RediTab® Plus or RediSpan® multi tier installation requires +/- 2250 mm per tier.
The floor itself has a +/- 100 mm height. The total available height required for a
2 tier installation will have be at least 4500 mm.**

Delivered unassembled.

On request our specialized installers will install your multi tier installation and it's accessories.
Ask for a free quote !



2 TIER INSTALLATION OR 1 TIER + MEZZANINE

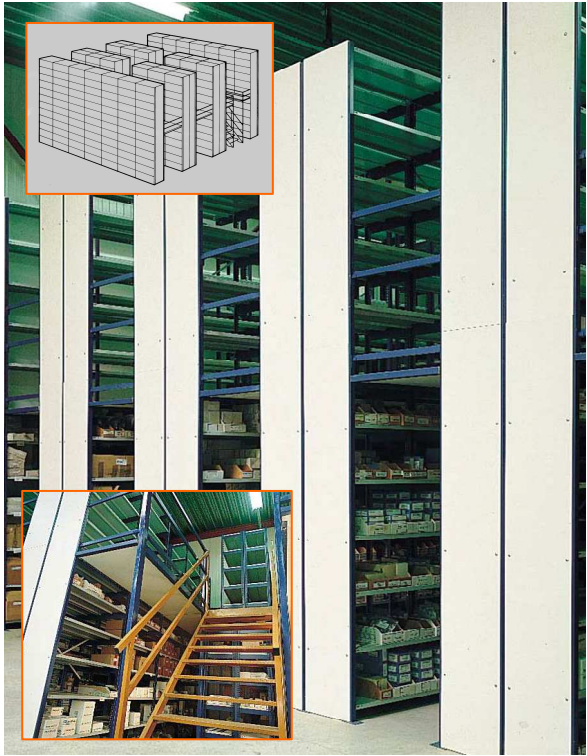

The 2 tier installation is most often built with the RediTab® Plus shelving system or the RediSpan® long span system

For storage of small parts, archives, etc.

Below and opposite you can view a few examples of multi tier installations for storage of small parts and archives built on the RediTab® shelving system.

Incorporated staircases and handrail are also available.

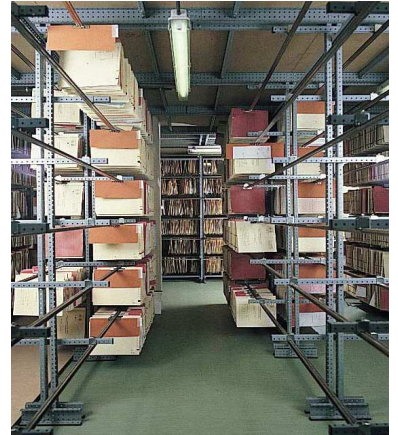
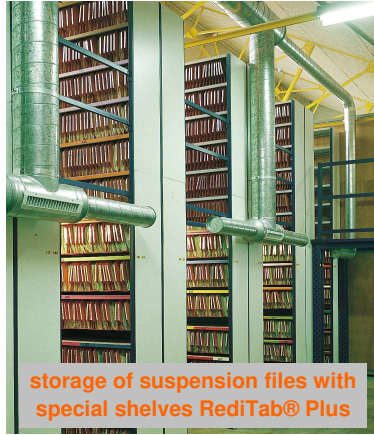

Opposite you can view a few multi tier installations built on the RediSpan® long span system.

RediTab® Plus shelving system below for storage of small parts and open mezzanine upstairs for storage of bulky goods on pallets or not.

RediSpan® long span below for storage of small parts or even more bulky goods, open mezzanine upstairs for storage of bulky goods on pallets or not.

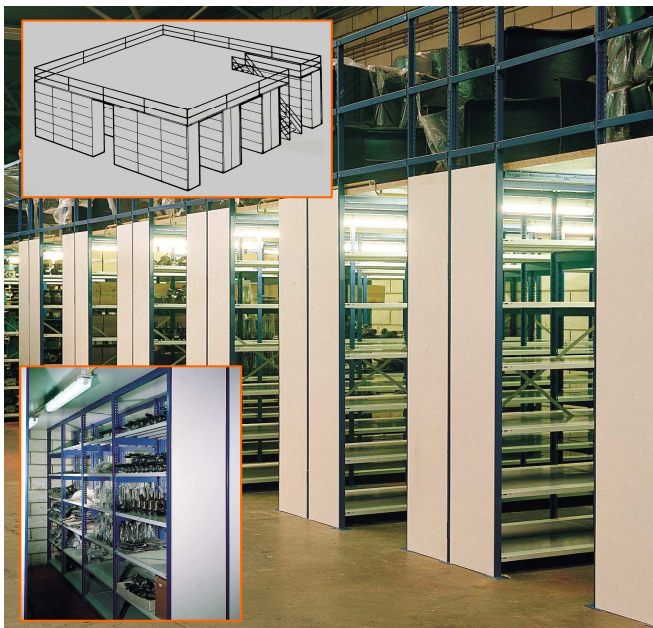

The mezzanine is built on top of the shelving system. Incorporated staircases and handrail are also available.

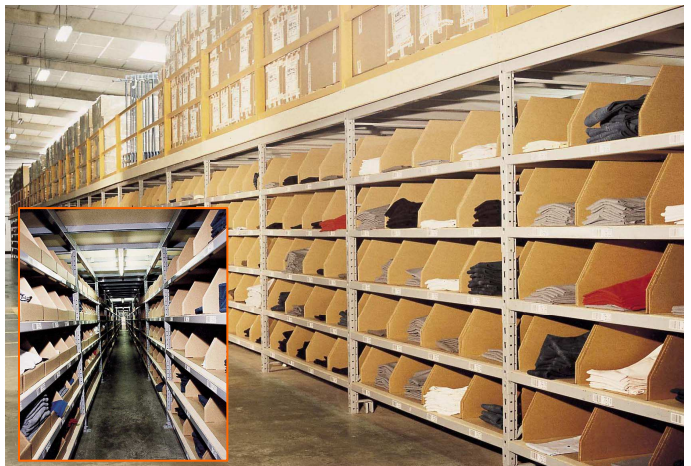

3 TIER INSTALLATION OR 2 TIER + MEZZANINE

The 3 tier installation is most often built with the RediTab® Plus shelving system or the RediSpan® long span system.
For storage of small parts, archives, etc.

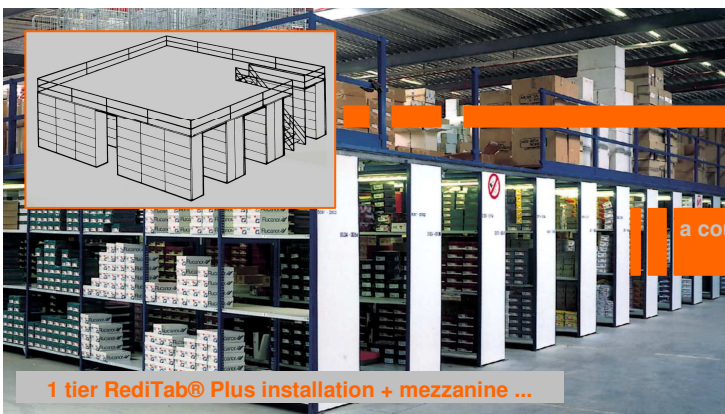
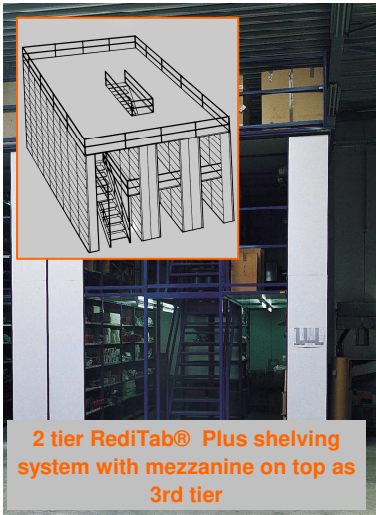

a couple of years later

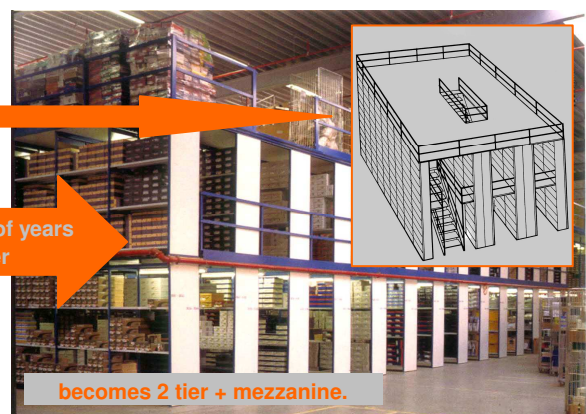

REDIDECK® • MULTI TIER GARMENT STORAGE

NEW : GARMENT STORAGE



1, 2, 3, 4, 5 ... tiers for hanging garment storage.

Possibility to block the garments per bay of 1500 mm or continuous storage without being hampered by the bracket.

Integration of conveyor belts is perfectly possible.

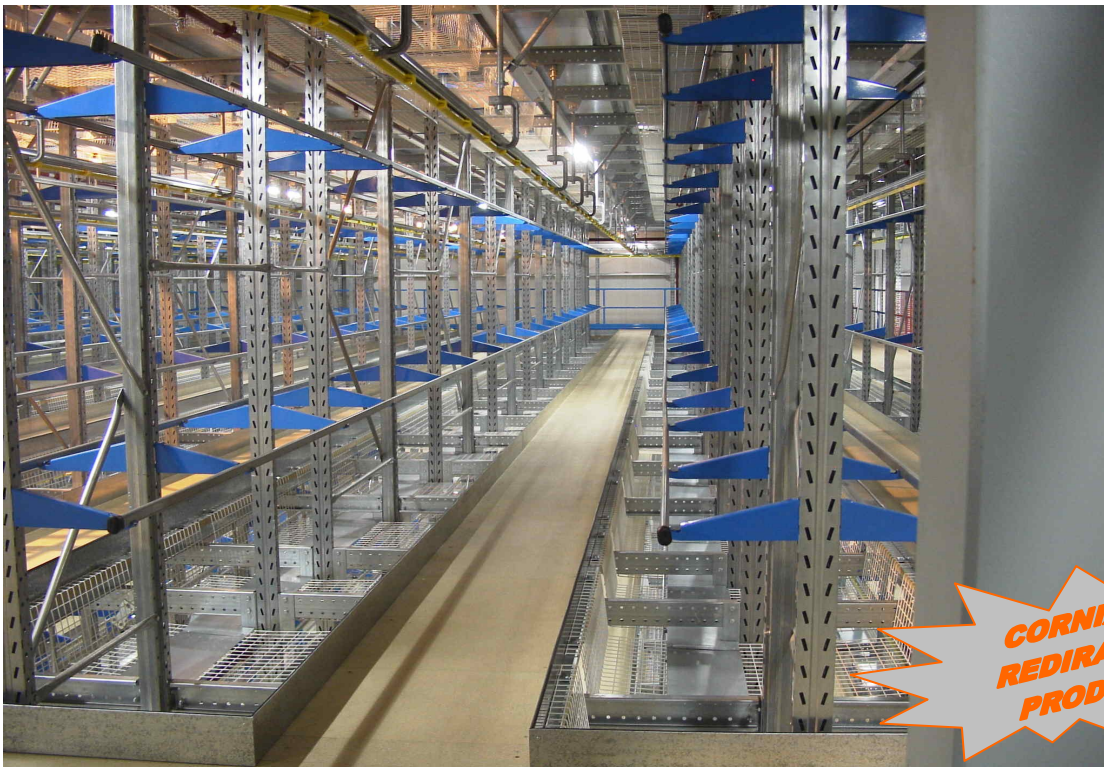

The brackets can also be used to carry a wire shelf.

Safety plinths in the passage ways.

Wire baskets under the brackets let the light through but avoid goods falling down on the level below.

**CORNIX
REDIRACK
PRODUCT**

REDIDECK® • HANDRAIL



For safety reasons every mezzanine should have a handrail of some kind. This handrail usually consists of a minimum of 2 tubes (one on hand height and one on knee height) and a plinth. We can supply a classic plinth but the picture opposite shows you a handrail set 38 mm with a plinth finishing the edge of your 38 mm thick floor. This plinth incorporates the 38 mm floor panel giving it a more esthetical view of your mezzanine. Standard finishing : blue RAL 5010 or yellow RAL 1018. Other colours are available at extra cost. Don't forget to order the plastic tube caps 50x30 mm in order to finish the edges of the handrail tubes. A handrail loading gate is also available on request.

DESCRIPTION	CODE	€
Handrail post 1050(+38) x 50 x 50 mm	CPOTC10550503	
Handrail set 1500 mm (= 2 tubes 50 x 30 + plinth +38)	CBALC15050303	
Handrail set 1800 mm (= 2 tubes 50 x 30 + plinth +38)	CBALC1C050303	
Handrail set < 1500 mm (= 2 tubes 50 x 30 + plinth +38)	CBALC00050303	
Angle for tube 50x30	CRACT50B3	
Angle for plinth +38	CRACPLB3	
Plastic cap 50 x 30 mm	JPP5030N0	

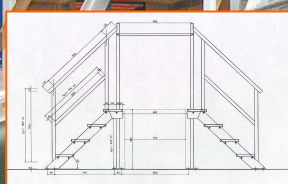
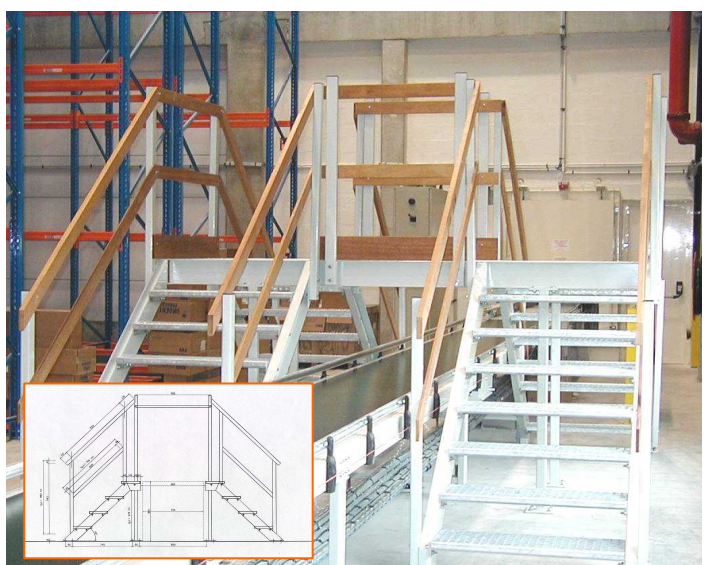

REDIDECK® • STAIRCASES



For the most up to date price : please consult us

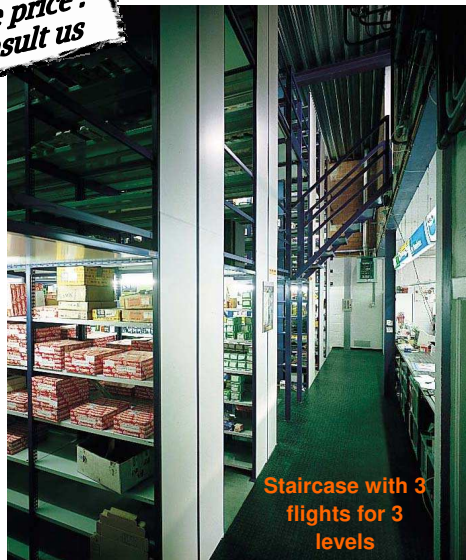

Steel staircases with handrail : 2 types of slope angles are available : 38° for use as main staircase and 45° for use as secondary staircase.

Blue RAL 5010 or yellow RAL 1018 finishing, other colours are available at extra cost. An entirely galvanized type for exterior use is also available.

The steps, 230 mm (45°) or 255 mm (38°) deep and entirely galvanized, are manufactured from perforated steel plate making them 100 % anti-skid.

Several widths are available : 700, 800, 900 en 1000 mm (other widths on request). The total width of the staircase is always 100 mm more than the step width because of the stringboards (2 x 50 mm). The usual fixing materials are standard supplied with the staircase. Overleaf you can find a outline of a few types of staircases with a step width of 800 mm which is the most common step width. We remain at your disposal for a free quote for these staircases or for any other type or dimension you might require.

A top landing with handrail is also available.

Delivered unassembled.

Easy installation. On request our specialized installers can install your staircase and handrail.

Ask for a free quote !



Redirack

**EUROPE'S FIRST MANUFACTURER
OF STORAGE SYSTEMS**

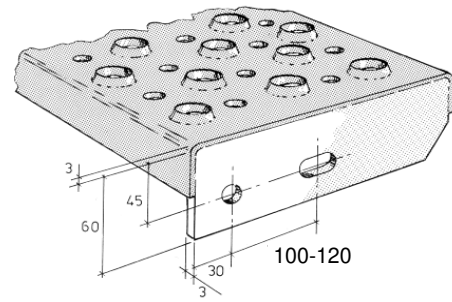
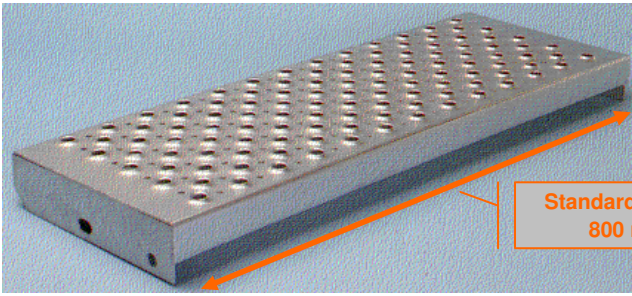

38° MAIN STAIRCASE (step depth 255 mm)

H (mm)	BASE (mm)	STEPS (number)	Step width : 800 mm CODE	€
790	1011	3	CEB388003X4	
865	1107	4	CEB388004X4	
940	1203	4	CEB388004X4	
1015	1299	5	CEB388005X4	
1090	1395	5	CEB388005X4	
1165	1491	5	CEB388005X4	
1240	1587	6	CEB388006X4	
1315	1683	6	CEB388006X4	
1390	1779	7	CEB388007X4	
1465	1875	7	CEB388007X4	
1540	1971	8	CEB388008X4	
1615	2067	8	CEB388008X4	
1690	2163	8	CEB388008X4	
1765	2259	9	CEB388009X4	
1840	2355	9	CEB388009X4	
1915	2451	10	CEB388010X4	
1990	2547	10	CEB388010X4	
2065	2643	10	CEB388010X4	
2140	2739	11	CEB388011X4	
2215	2835	11	CEB388011X4	
2290	2931	12	CEB388012X4	
2365	3027	12	CEB388012X4	
2440	3123	13	CEB388013X4	
2515	3219	13	CEB388013X4	
2590	3315	13	CEB388013X4	
2665	3411	14	CEB388014X4	
2740	3507	14	CEB388014X4	
2815	3603	15	CEB388015X4	
2890	3699	15	CEB388015X4	
2965	3795	15	CEB388015X4	
3040	3891	16	CEB388016X4	
3115	3987	16	CEB388016X4	
3190	4083	17	CEB388017X4	
3265	4179	17	CEB388017X4	
3340	4275	18	CEB388018X4	
3415	4371	18	CEB388018X4	
3490	4467	18	CEB388018X4	
3565	4563	19	CEB388019X4	

45° SECONDARY STAIRCASE (step depth 230 mm)

H (mm)	BASE (mm)	STEPS (number)	Step width : 800 mm CODE	€
790	790	3	CEB458003X4	
865	865	4	CEB458004X4	
940	940	4	CEB458004X4	
1015	1015	5	CEB458005X4	
1090	1090	5	CEB458005X4	
1165	1165	5	CEB458005X4	
1240	1240	6	CEB458006X4	
1315	1315	6	CEB458006X4	
1390	1390	7	CEB458007X4	
1465	1465	7	CEB458007X4	
1540	1540	8	CEB458008X4	
1615	1615	8	CEB458008X4	
1690	1690	8	CEB458008X4	
1765	1765	9	CEB458009X4	
1840	1840	9	CEB458009X4	
1915	1915	10	CEB458010X4	
1990	1990	10	CEB458010X4	
2065	2065	10	CEB458010X4	
2140	2140	11	CEB458011X4	
2215	2215	11	CEB458011X4	
2290	2290	12	CEB458012X4	
2365	2365	12	CEB458012X4	
2440	2440	13	CEB458013X4	
2515	2515	13	CEB458013X4	
2590	2590	13	CEB458013X4	
2665	2665	14	CEB458014X4	
2740	2740	14	CEB458014X4	
2815	2815	15	CEB458015X4	
2890	2890	15	CEB458015X4	
2965	2965	15	CEB458015X4	
3040	3040	16	CEB458016X4	
3115	3115	16	CEB458016X4	
3190	3190	17	CEB458017X4	
3265	3265	17	CEB458017X4	
3340	3340	18	CEB458018X4	
3415	3415	18	CEB458018X4	
3490	3490	18	CEB458018X4	
3565	3565	19	CEB458019X4	



Other widths available : 700, 900, 1000 en 1200 mm

**Staircases for industrial use only.
Not suited for premises accessible to the public.**

HANDRAIL LOADING GATE

A handrail loading gate is also available on request.
Maximum aperture width 1400 mm.







YOUR CHOICE OF COLOURS

Standard colour for this product (4 to 6 weeks) :

Gentian blue ral 5010 
 (bracing & small items : sendzimir)

Other standard colours without surcharge
 (lead time 4 to 6 weeks) :

Ivory (cream) ral 1013 
 Zinc yellow ral 1018 
 Orange-red ral 2002 
 Light grey ral 7035 
 (bracing & small items always sendzimir)

Other ral colours at extra cost (lead time +/- 6 weeks)

(bracing & small items always sendzimir).

Hot dipped galvanized version available at extra cost (+/- 6 weeks).

OTHER REDIRACK® PRODUCTS



RediRack
Pallet racking



RediBuild
Covered storage



RediDrive
Drive-in & drive-through

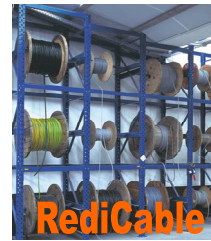

RediCable
Cable drum storage



RediCant
Cantilevers



RediTab
Shelving systems

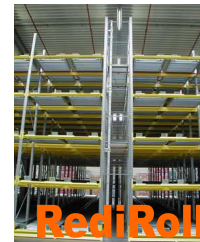

RediRoll
Dynamic storage



RediSpan
Long span



STORAGE SYSTEMS FOR LIFE

www.redirack.eu

REDIRACK FLANDERS ANTWERPEN (Kiel)

Boomssteenweg, 492
 B-2020 Antwerpen

☎ ++/32/(0)3/240 11 30
 📠 ++/32/(0)3/825 30 90
 ✉ sales@cornix.eu

REDIRACK NETHERLANDS DOETINCHEM (no showroom)

Kruidenlaan 7
 NL-7060 TD Doetinchem

☎ ++/32/(0)3/240 11 30
 📠 ++/32/(0)3/825 30 90
 ✉ sales.nl@cornix.eu

REDIRACK WALLONIA NIVELLES

Rue de la Recherche 6A, Z.I. 1 Nivelles Sud
 B-1400 Nivelles

☎ ++/32/(0)67/411 241
 📠 ++/32/(0)67/411 249
 ✉ sales@cornix.be

REDIRACK EXPORT SALES NIVELLES

Rue de la Recherche 6A, Z.I. 1 Nivelles Sud
 B-1400 Nivelles

☎ ++/32/(0)67/894 225
 📠 ++/32/(0)67/894 220
 ✉ export@cornix.eu